



회사소개서

(주)지티에스
GLOBAL TECHNOLOGY SYSTEM CO., LTD



Contents

- 01/ About GTS
- 02/ History & Today
- 03/ 주요 생산 품목 ,생산 Capacity
- 04/ 제품 개발 현황
- 05/ 장비 개발/제작 및 보유 현황
- 06/ Agent Supply Items
- 07/ 제어시스템 개발이력
| Control System Development History

01

About GTS

- Vision



본사(경기 군포 IT 밸리)

사업장	위치	설립 년도	회사규모	주요생산품
(주)지티에스	경기군포	2024. 10	300평	NFC COIL ANT외 / 신제품 개발

01

About GTS

- Vision

Global Manufacturing optic & Telecommunication solution company

기존사업 질적 성장

- NFC CHIP ANT 매출 극대화
 - Galaxy Watch 1~7 개발 및 생산
 - Galaxy Watch 8 개발 및 생산
 - Galaxy Watch 9 개발 및 생산 예정
- INDUCTOR COIL
 - 양산
 - 개발 샘플 적극적인 진입 시도.

신규사업 확대

- 안정적 사업 진입 목표
 - 독일 인덕션 쿠키 개발 및 생산 예정
- 해외 사업 확대
 - 전략적 협업을 통한 중국 내 활동 강화
 - 해외 신규 거래선 발굴(일본/중국/기타)

핵심 가치 실현

- Technical Value 극대화
 - 다양한 분야의 로봇 적용 분야 개발
 - 신규 고객사 확보 및 다양성 구축
 - 핵심 요소 기술 구축
 - 시스템 구축을 통한 저비용 고효율 검토.
- 3정 실천
(정성, 정직, 정도)

01

About GTS

- GTS 강점

(1) 고객 지향

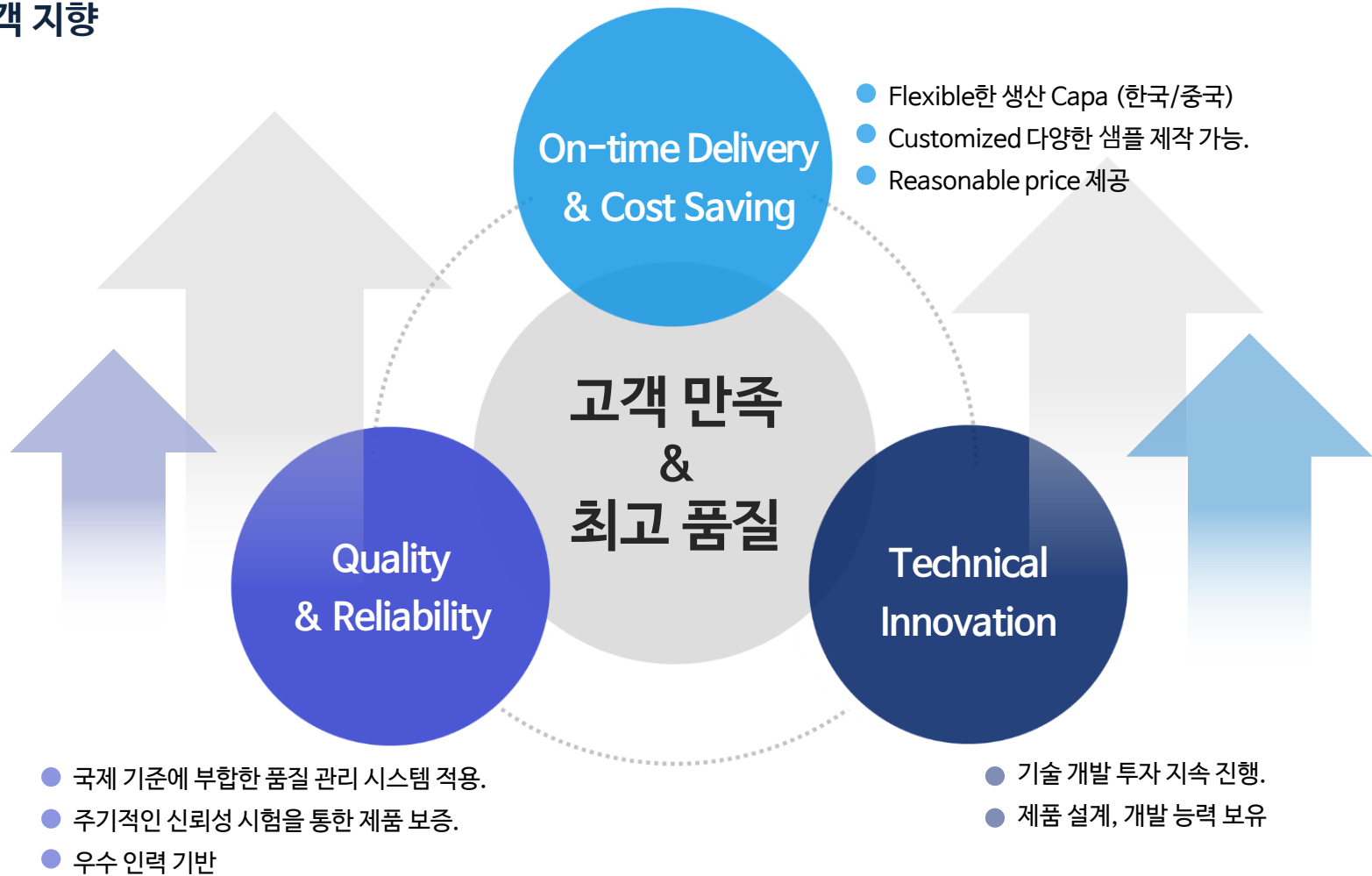

01

About GTS

- GTS 강점

(2) 안정된 품질 관리

고객만족 실현

- 국제 표준에 의거한 검사 시험
- 안정된 Process를 통한 양질의 제품 제공

출하 품질 보증

ISO 2859-1 검사 실시
외관/치수/형합/특성/성능 검증
고객 불만 사항 해결

부품 품질 보증

수입검사기준서/성적서 관리
ISO 2859-1 검사 실시.
검,교정된 계측기기 사용

공정 품질 보증

CTQ 공정 관리
공정 Patrol
작업자/검사자 인증 제도
LOT 추적 시스템
공정 품질 Audit 실시

제품 품질 보증

개발 품질 보증

단계별 품평회
검증된 환경 물질 사용 (RoHS, MSDS 기준)

01

Motor Industry Solutions created by GTS

- GTS 강점



다양한 코일 및 모듈 제조

- 카메라 액추에이터 코일
- 진동 모터 코일
- BLDC 모터 코일
- NFC 코일
- Wire Harness
- Busbar



기계 설계 및 구현

- 무보빈/보빈형 코일 권선 기계
- 진동 모터 테스트 및 제조 기계
- BLDC 모터 권선 기계
- AF/OIS 카메라 테스트 기계
- 바이오 테스트 기계: DNA 추출기
- 해동기, 바이오 리액터 등



모터 관련 제어 시스템 구현

- 일반 목적 로봇 제어기
- 진동 모터 테스트 시스템
- BLDC 모터 와인더 제어 시스템
- 일반형 무보빈/보빈형 권선 제어 시스템
- CNC 제어 시스템



시스템 솔루션 제공업체

- 상업적 및 산업적 솔루션
- (전자 하드웨어/소프트웨어 및 기계 하드웨어 등)

01

About GTS

- 주요 고객사 현황

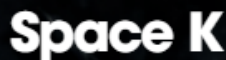

“ We hope you will be the next ”

02

History & Today

- 제품 Trend

History

Today

Coil Line up



Hard Disk Ass'y



Motor Coil Ass'y



Coil Ass'y



AF or OIS Coil

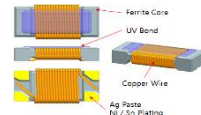

NFC CHIP ANTENNA



편각 Coil



차량용 Busbar

Coil / Busbar / Etc.



Equipment Line up



BOBBIN LESS 권선기



알파 권선기



3D PRINT



자동 용접기



외관/주파수/LCR 자동 검사 및 포장시스템



편각 Coil 권선기



일립스 권선기

Dental item

Winding Machine ROBOT + AI Machine

Development Item

Development Line up



휴대용 배터리



인공호흡기 배터리 팩 Ass'y



휴대용 용접기



한국전력 검전기



All-Free Zone 인덕션

Agent Supply Item

Agent Supply Item Line up

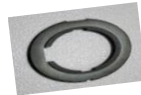

Ferrite



Ferrite & Coil



NANO Ribbon



NANO Sheet

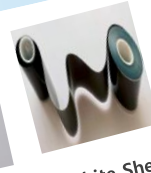

Graphite Sheet

03

제품별 소개

인휠모터

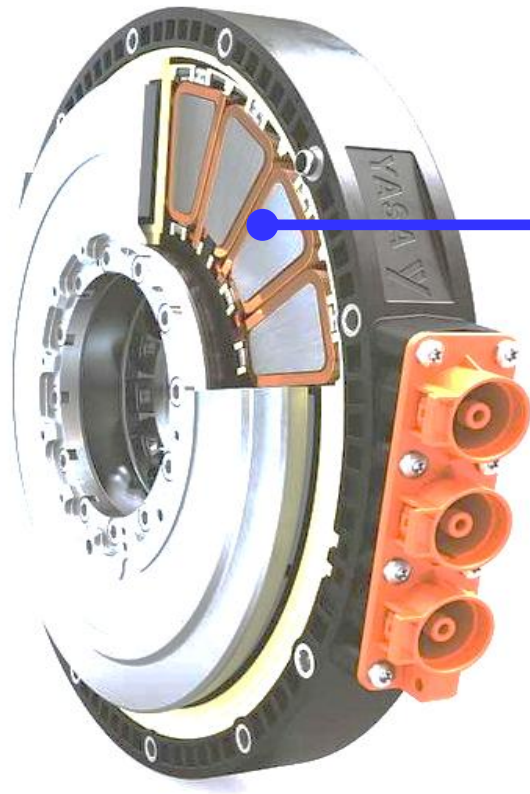

03

제품별 소개

NFC CHIP ANTENNA

세계최초 CHIP NFC ANTENNA 적용 (SAMSUNG GEAR)

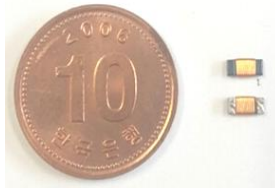
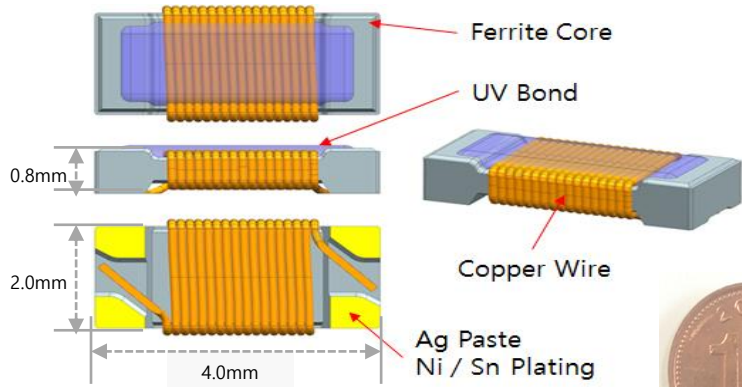

NFC ANT. COIL ASS'Y



단축 권선기 → 잔사 커팅 → 코어 정열기 → 1차 검사 → UV 코팅기 → UV 경화기 → 2차 검사 → 자동 검사포장기

03

주요 생산 품목 및 연간 생산 Capacity

- 제품 관련 항목

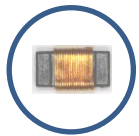

CHIP NFC Antenna

10,000,000 PCS



Inductor Coil

2,500,000 PCS



Coil

25,000,000 PCS



Etc. Machine

-

04

COIL 제품 개발/생산 현황

제품

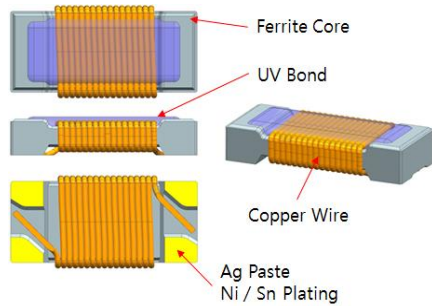

NFC CHIP ANTENNA



Coil Ass'y (AF or OIS)

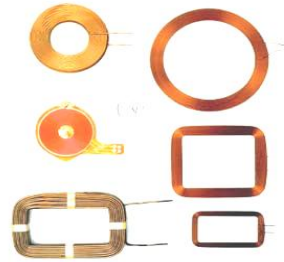

Busbar



편각 Coil



Hard Disk Ass'y



Motor Coil Ass'y



Coil Ass'y

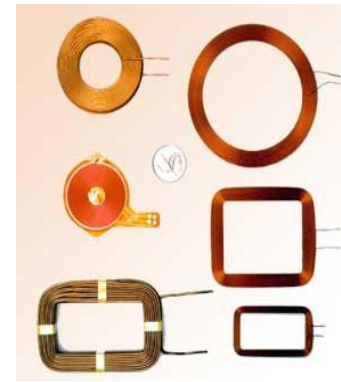

RF Coil Ass'y



Solenoid coil Ass'y

Coil Winding Item

04

COIL 제품 개발/생산 현황

모터코일 제품

Coil Winding Item

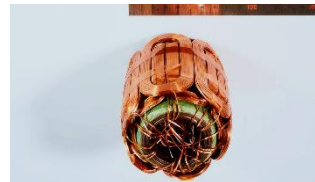
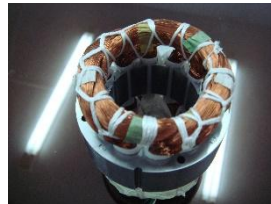

04

COIL 제품 개발/생산 현황

Coil Winding Item

무선충전코일 제품

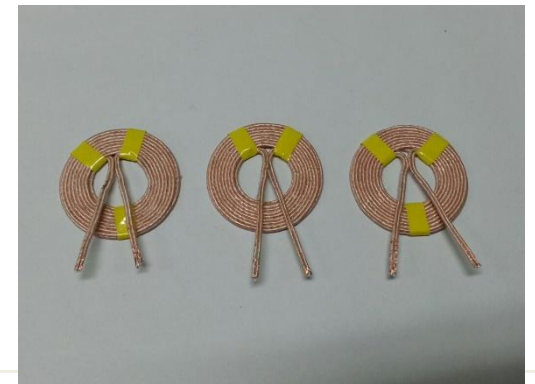
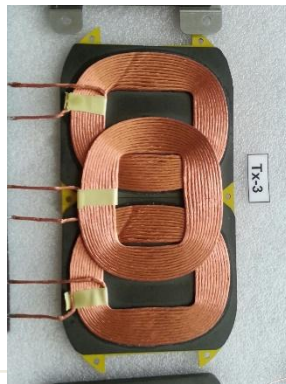
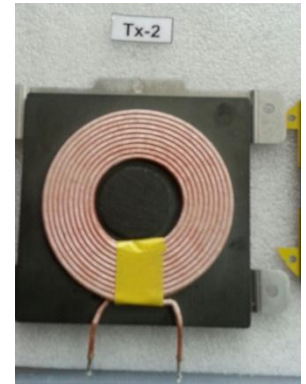
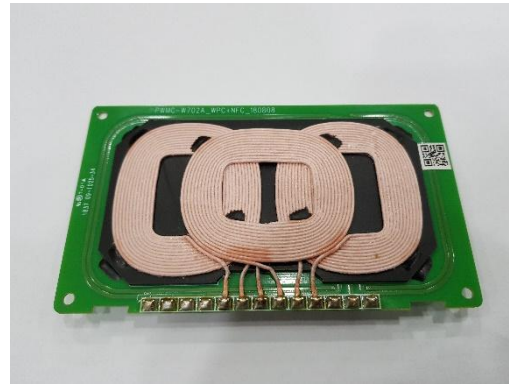
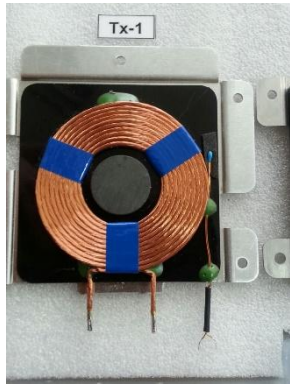

04

COIL 제품 개발/생산 현황

Coil Winding Item

버스바코일 제품

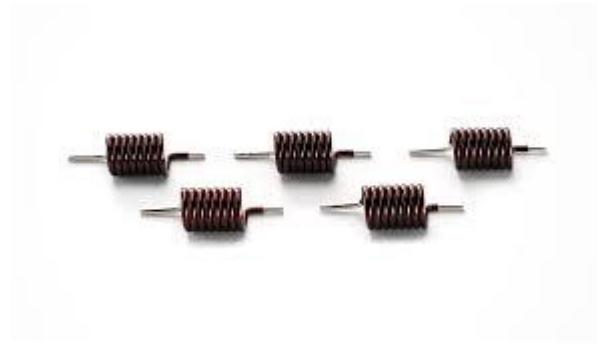

04

COIL 제품 개발/생산 현황

Coil Winding Item

보빈레스코일 제품

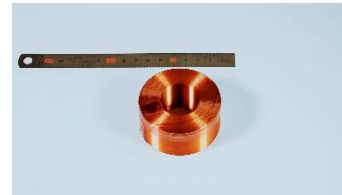
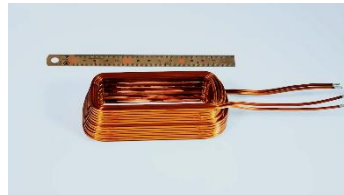
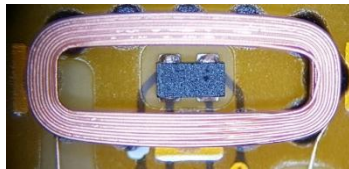
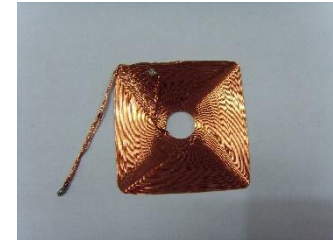
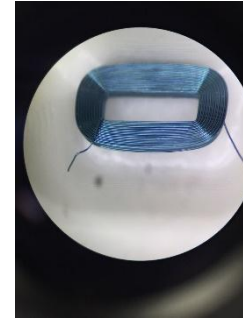
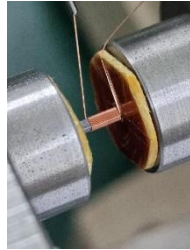
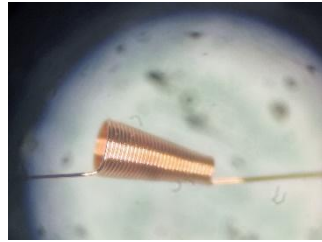

04

COIL 제품 개발/생산 현황

Coil Winding Item

보빈코일 제품

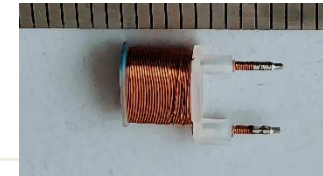
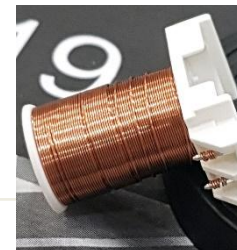
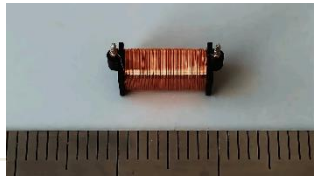
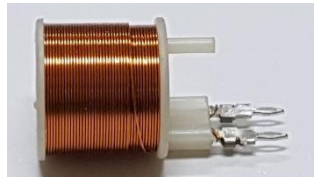

04

COIL 제품 개발/생산 현황

Coil Winding Item

센서코일 Ass'y 제품

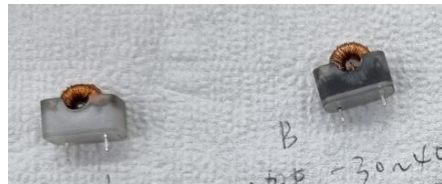
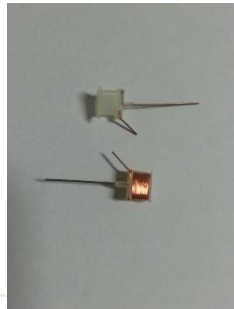
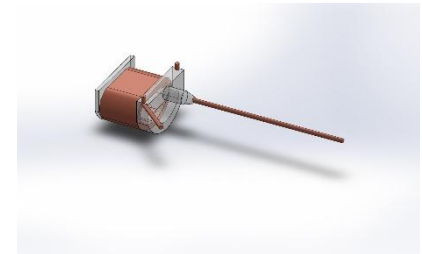
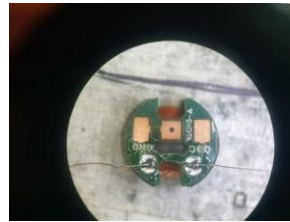
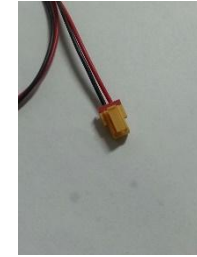
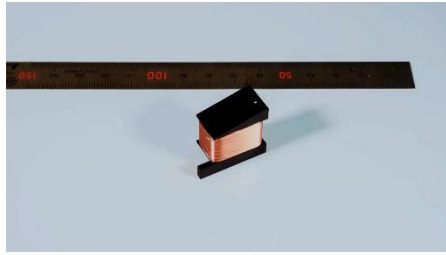

04

COIL 제품 개발/생산 현황

안테나코일 제품

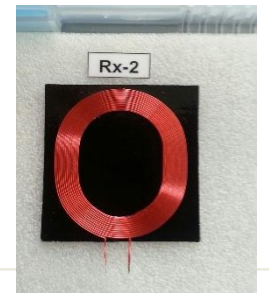
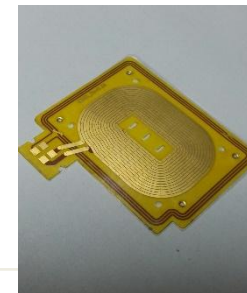
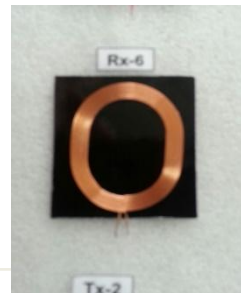
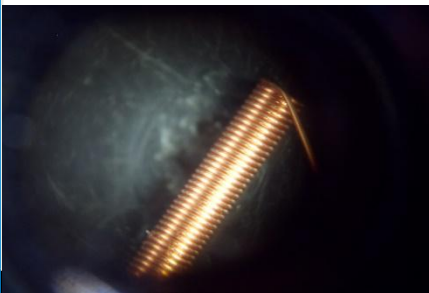
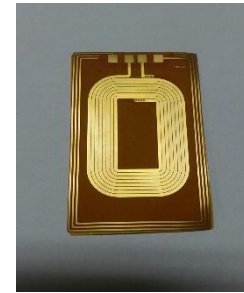
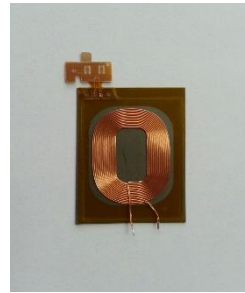
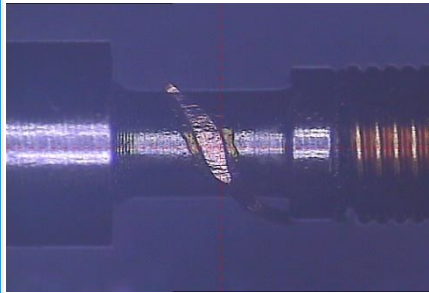
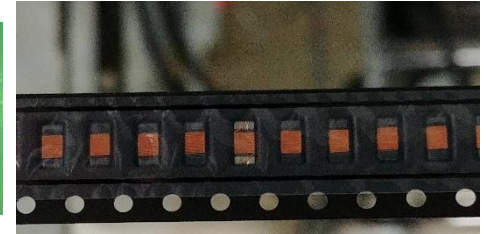
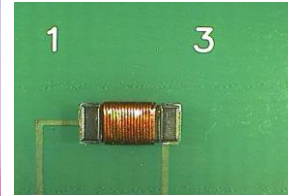
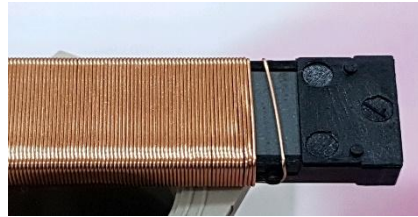
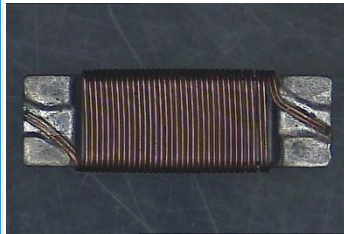

Coil Winding Item

04

COIL 제품 개발/생산 현황

에어코일 제품

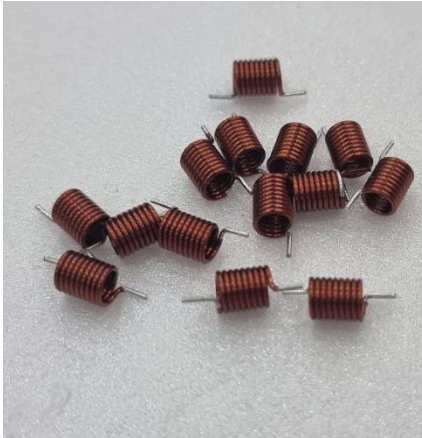

04

COIL 제품 개발/생산 현황

연속코일 제품

Coil Winding Item

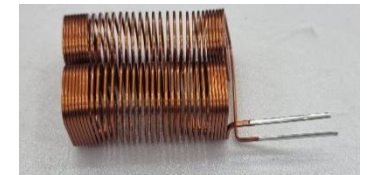
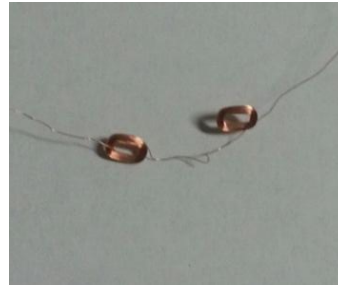
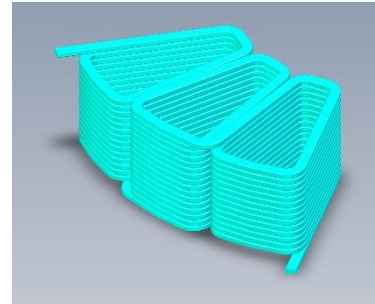

04

COIL 제품 개발/생산 현황

Coil Winding Item

인덕션코일 제품

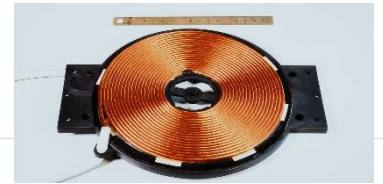
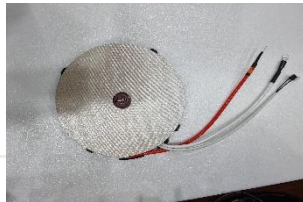
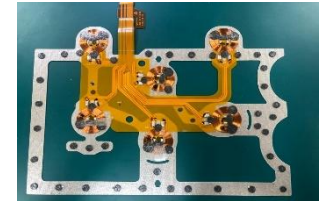
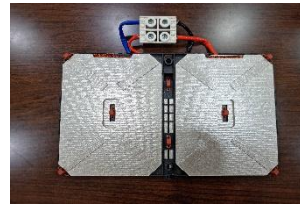
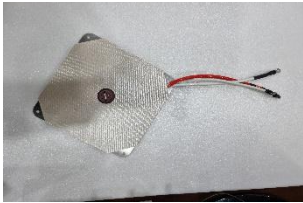

04

COIL 제품 개발/생산 현황

임베디드코일 제품

Coil Winding Item

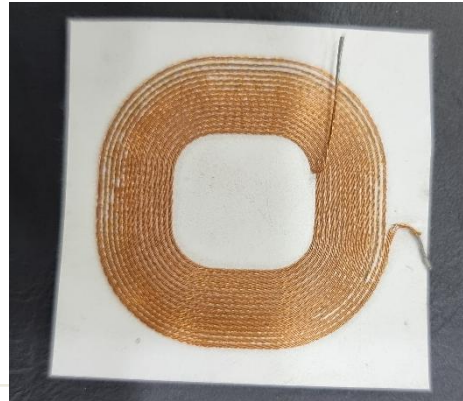
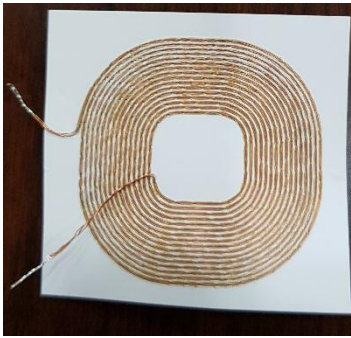

04

COIL 제품 개발/생산 현황

Coil Winding Item

인휠모터코일 제품

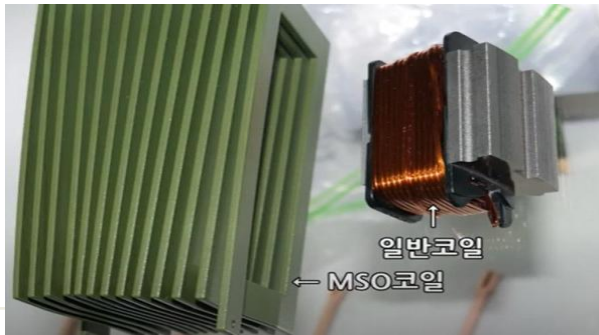
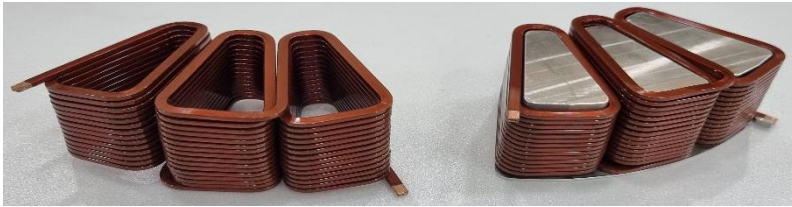

04

COIL 제품 개발/생산 현황

카메라코일 제품

Coil Winding Item

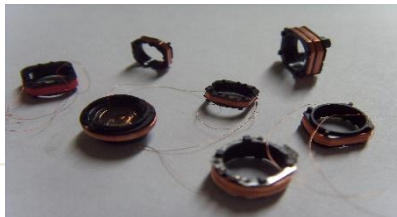
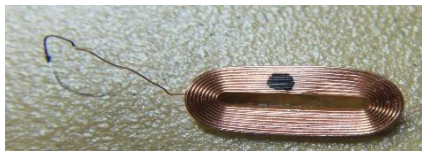
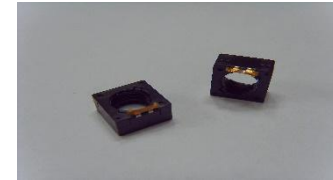
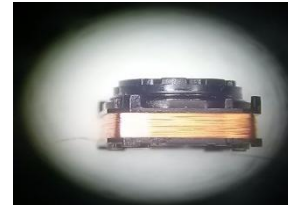
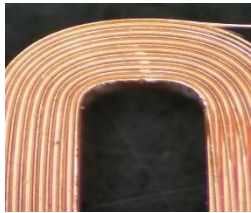
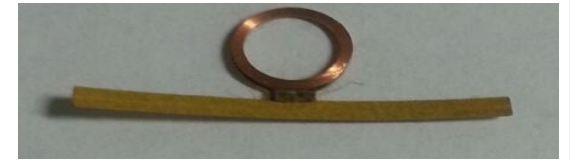
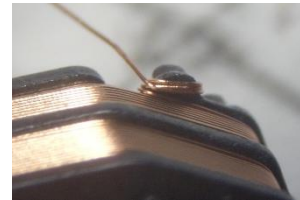
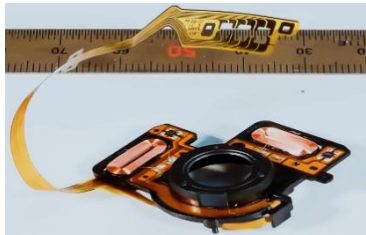

04

COIL 제품 개발/생산 현황

Coil Winding Item

트렌스코일 제품

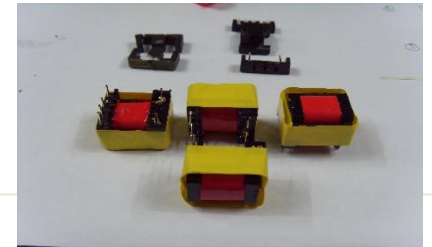
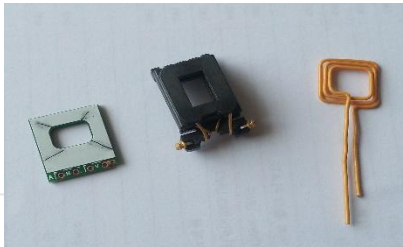
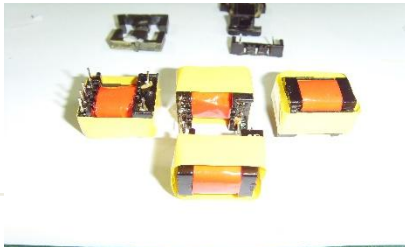
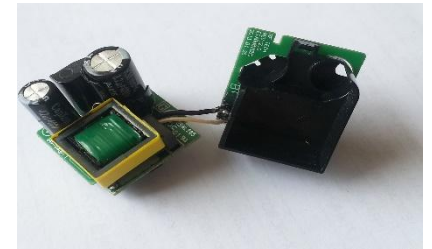
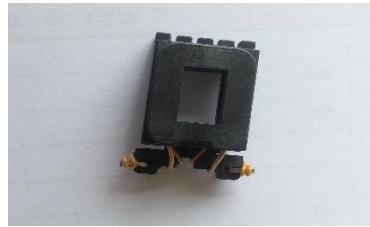
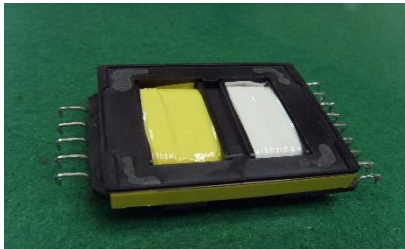
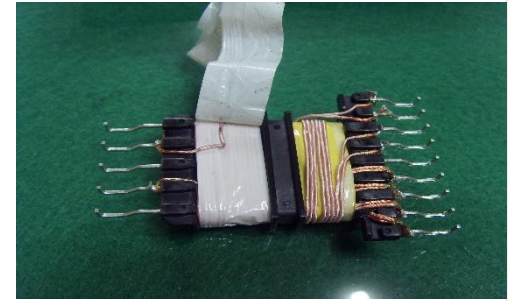
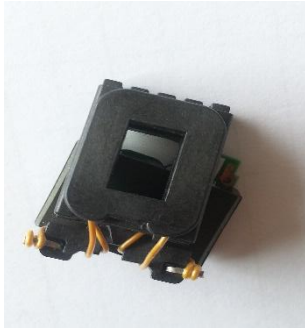

04

COIL 제품 개발/생산 현황

Coil Winding Item

트로이달코일 제품

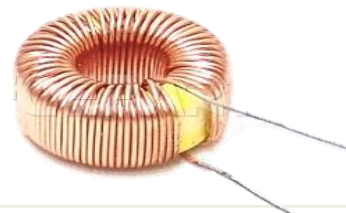
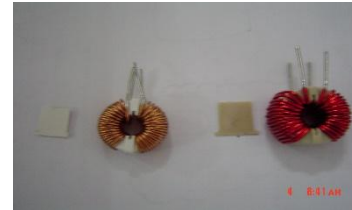
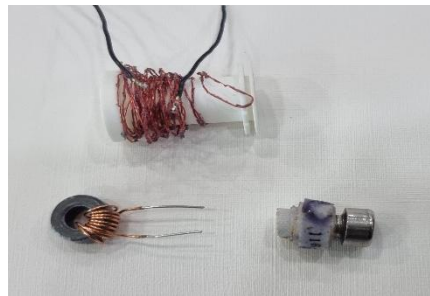
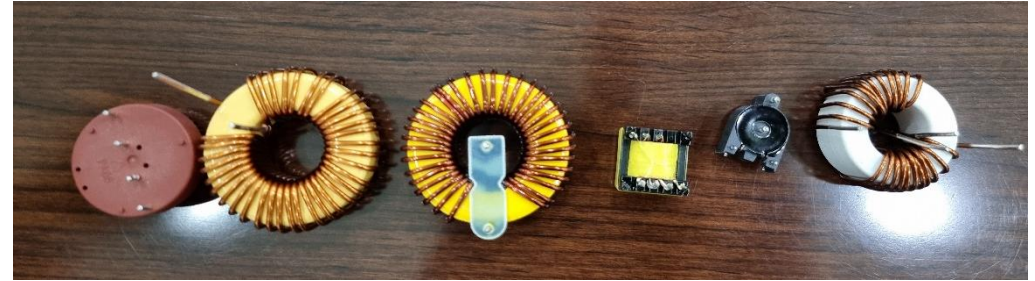
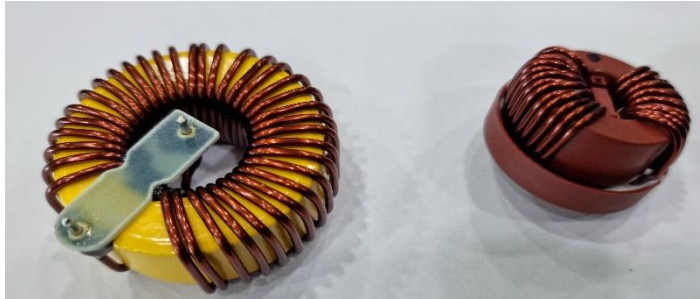

04

COIL 제품 개발/생산 현황

Coil Winding Item

특수코일 제품

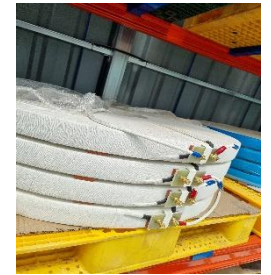
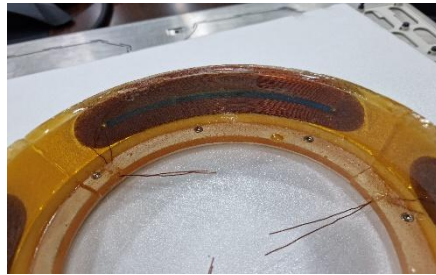
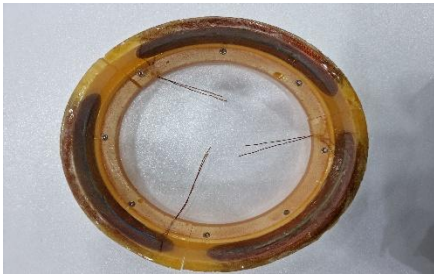
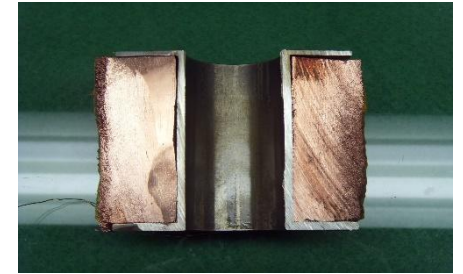
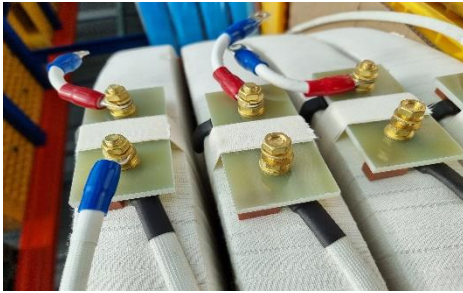

04

COIL 제품 개발/생산 현황

편각코일 제품

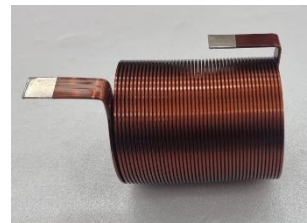
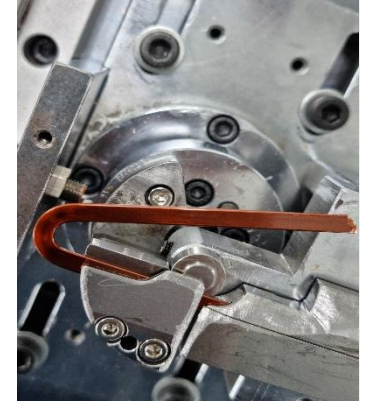

Coil Winding Item

제품



12 spindle 61.2 wheelbase automatic winding and coating machine



12-spindle 72-wheelbase double-coated manual loading and unloading winding machine



8-spindle automatic valve production line



20-spindle full-automatic winding and gluing machine



Motor coil, high voltage package with solder test production line

제품



Automatic Laser Soldering Production Line for Winding and Basing of Transformer



Automatic Laser Soldering Production Line for Winding and Basing of Transformer



Automatic Laser Soldering Production Line for Winding and Basing of Transformer



Fully automatic non-standard production line



Automatic transformer production line

05

장비 개발/제작 및 보유현황

제품



편각선 권선기



알파 권선기



다이아몬드 권선기



권선기



Core 권선기



권선기



권선기

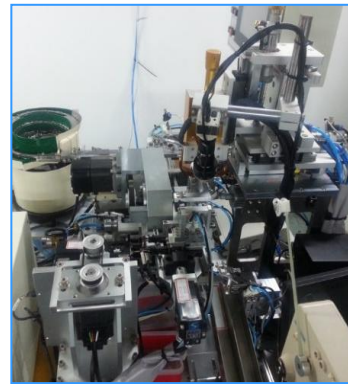

권선기



편각 일립스 권선기



편각 원형 권선기



DMB 권선기

Winding Machine

05

장비 개발/제작 및 보유 현황

제품



릴 자동 포장기



Core 자동 정렬기



UV 도포기



UV 경화기

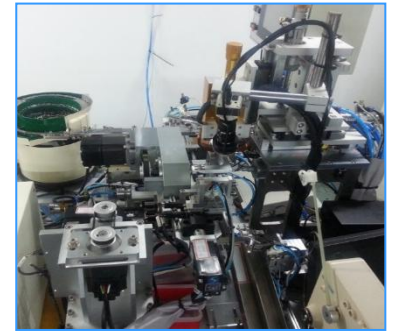

DMB WIND M/C



릴 자동 포장기



3D 프린터

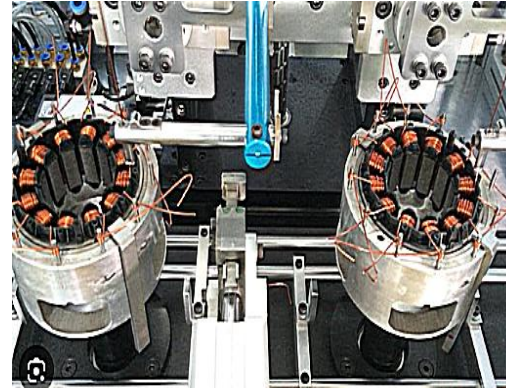

BLDC motor coil winding machine



Troidal coil auto winding machine

Machine

05

장비 개발/제작 및 보유 현황

인공위성 전기추력기 (FEEP)

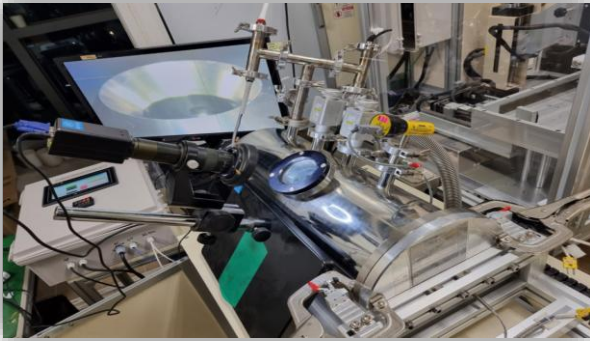

진공챔버

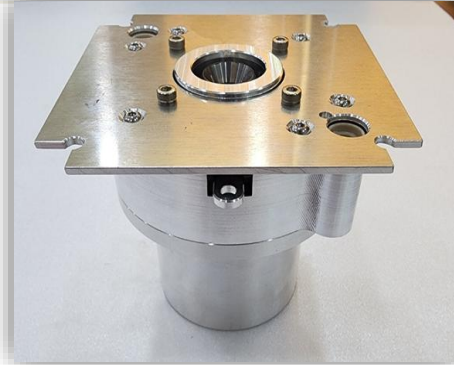

인공위성 전기 추력기

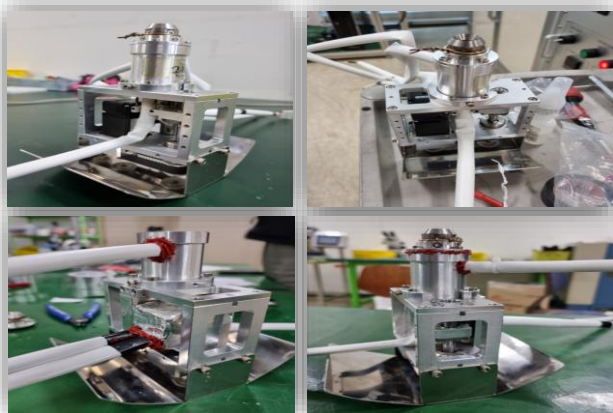

진공 챔버 내 추력기 동작 TESTER 기

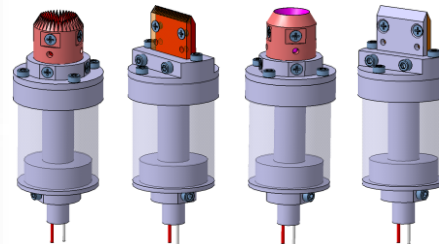

부품 구성

05

장비 개발/제작 및 보유 현황

한전 고압선로 사할 검전기



06

제어시스템 개발이력 | Control System Development History

지티에스에서는 고객사 제품의 사양에 적합한 제어시스템을 수년동안 개발해왔으며, 다음의 제품들이 지티에스 연구소에서 개발되었습니다.

Coil Winding & Processing

- Bobbinless Coil Winder
- Bobbin type Coil Winder
- Power Inductor Winder
- BLDC Coil Winder
- NFC Coil Winder
- Auto Stone Setting Machine

Testing & Automation Systems

- Wire Harness Auto Tester
- 48ch DNA extractor system
- Auto Thawing Machine
- Camera AF/OIS Function Tester
- Steering Wheel Test System for Eelec-vehicle
- Vibrator motor-function tester
- Auto Aging Machine (Coin motor)
- Nose Inhaler system for Consumer market

06

제어시스템 개발이력 | Control System Development History

주요 개발 제품 현황 | Featured Product Showcase



06

제어시스템 개발이력 | Control System Development History

개발적용분야 | Development Application Field

Industrial Machinery

- 다축 로봇컨트롤 시스템
- **CNC**자동권선기
- **CNC** 가공장비

Bio & Testing

- 바이오 관련장비
(유전자 추출기 등)
- 각종성능검사장비
- **Auto Cable Tester**

Automation & Consumer

- 기타자동차 생산설비
- 소비자가전
(전동칫솔, 마사지기 등)
- 자동콧물흡입기

상세 리스트 | Detailed Specifications

- **Industrial:** Multi-axis robot, CNC Coil Winder, Machining
- **Bio:** Genetic extractors, Bioreactor, Biowelder, Cytopathletes
- **Testing:** Performance Inspection, Auto Cable Tester
- **Automation:** Other automated production facilities
- **Consumer:** Sonic Toothbrush, E-cigarette, Sports Massager, Nose inhaler

07

Agent Supply Items

제품 (Watch 부품군)

Main Products

- Rx / Tx Coil
- Ferrite Sheet
- Coil Block with PCB



Application

- Mobile
- Smart Watch
- Automotive
- Induction



Main Products

- Nano Ribbon
- Nano sheet
- Nano Core

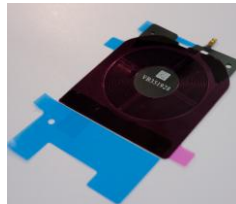
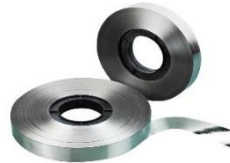

Application

- Automotive
- Mobile & Earbud
- EMI Filter
- Power Supply – EMC Filter

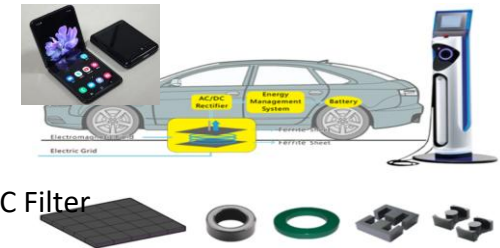

Main Products

- Vibration Motor
- Graphite Sheet
- TIM Pad
- Mica sheet

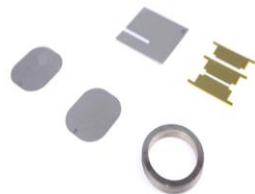

Application

- Automotive
- Electronic Cigarette
- Wireless Charger
- Induction



07

Agent Supply Items

제품 (Magnet & Ferrite & Battery군)

Main Products

- Magnetics (NdFeb) / Ceramic ferrite
- Battery

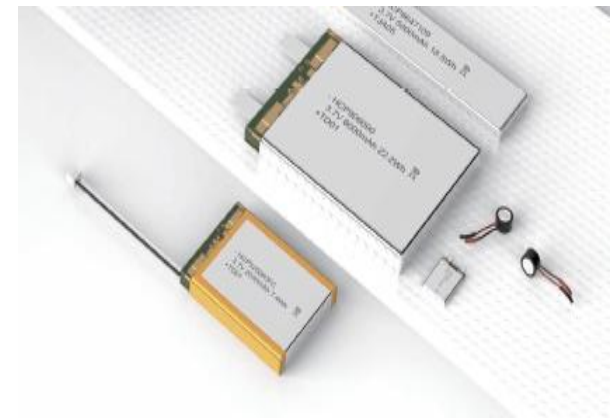

“Thank you.”